





QUICK GUIDE

Dear Customer,

We would like to congratulate and thank you for choosing a Fiat .

This Quick Guide will provide you with the main indications and some recommendations for the use of your Fiat .

This Quick Guide is not a substitute for the more in-depth reading of the complete Owner Handbook, which is available online.

The figures in this guide are only examples. This might imply that some details of the image do not correspond to the actual arrangement of your Fiat .

After reading it, you are advised to keep this Quick Guide inside the vehicle, for an easy reference and for making sure it remains aboard the car should it be sold.

In the attached Warranty Booklet you will also find a description of the Services that Fiat offers to its customers, the Warranty Certificate and the detail of the terms and conditions for maintaining its validity.

We are confident that these tools will bring you closer to your new car and make you appreciate the assistance provided by the Fiat team.

Enjoy reading. Happy motoring!

The data contained in this publication is intended to help you use your car in the best possible way. FCA Italy S.p.A. aims at a constant improvement of the vehicles produced. For this reason it reserves the right to make changes to the model described for technical and/or commercial reasons. For further information, contact a Fiat Dealership.

ONLINE OWNER HANDBOOK

FCA is committed to protecting the environment and invites you to refer to the Complete Owner Handbook in digital form, via the QR code on this page or on the internet pages listed below.



Go to the **www.mopar.eu/owner** website and access your personal area.

The "Maintenance and care" page includes all the information about your vehicle and the link to access eLUM, where you will find all the details of the Owner Handbook.

Alternatively, to access this information, go to the Internet website at **<http://aftersales.fiat.com/elum/>**.

The eLUM website is free and conveniently allows you to browse the on-board handbooks of all other models of the Group, among many other things.

Have a nice read and happy motoring!

CONTENTS

CAR INTERIOR	5
MANUAL CLIMATE CONTROL SYSTEM	5
AUTOMATIC CLIMATE CONTROL SYSTEM	6
MULTIFUNCTION DISPLAY	6
COLOUR DISPLAY	7
HYBRID SYSTEM SCREENS.....	8
WARNING LIGHTS AND MESSAGES	9
RED WARNING LIGHTS/ SYMBOLS.....	9
AMBER WARNING LIGHTS/ SYMBOLS.....	9
GREEN WARNING LIGHTS/ SYMBOLS.....	11
BLUE WARNING LIGHTS/ SYMBOLS.....	11
WHITE WARNING LIGHTS/ SYMBOLS.....	11
MESSAGES.....	11
THE KEYS	11
DUALOGIC TRANSMISSION	11
MANUAL MODE.....	11

AUTOMATIC LOGIC (AUTO)	12
ECO FUNCTION.....	12

EXTERNAL LIGHTS	12
DAYTIME RUNNING LIGHTS (DRL)	12
DIPPED BEAM HEADLIGHTS/ SIDE LIGHTS.....	12
MAIN BEAM HEADLIGHTS.....	12
FLASHING THE HEADLIGHTS	13
PARKING LIGHTS	13
AUTO FUNCTION.....	13
DIRECTION INDICATORS.....	13
FOG LIGHTS/REAR FOG LIGHTS	13

MOPAR® CONNECT	14
SERVICES.....	14

CHILD RESTRAINT SYSTEMS	15
PASSENGER'S FRONT AIRBAG AND CHILD RESTRAINT SYSTEMS.....	15
DEACTIVATING THE PASSENGER SIDE AIRBAGS: FRONT AIRBAG AND FRONT SIDE BAG...	15

iTPMS (indirect Tyre Pressure Monitoring System)	16
---	----

CHANGING A WHEEL	17
CHANGING PROCEDURE.....	17

FIX & GO KIT	21
TYRE REPAIR PROCEDURE	21

REPLACING A BULB	24
FRONT LIGHT CLUSTERS	24
REAR LIGHT CLUSTER.....	25

FUSES	27
--------------------	----

SCHEDULED SERVICING	28
SERVICE SCHEDULE.....	28

REFILLING	32
------------------------	----

UCONNECT™ RADIO	34
------------------------------	----

UCONNECT™ 5" RADIO/ NAV	35
CONTROLS ON THE STEERING WHEEL	35
PAIRING A MOBILE PHONE.....	35

Uconnect™ 7 HD/ NAV	36
CONTROLS ON THE STEERING WHEEL	37
PAIRING A MOBILE PHONE.....	37

WHEELS	38
---------------------	----

COLD TYRE INFLATION
PRESSURE (bar)38

**OFFICIAL TYPE
APPROVALS.....38**

SUPPLEMENTS

EURO 5 - EURO 6B.....



AUSTRALIA VERSION.....



CAR INTERIOR

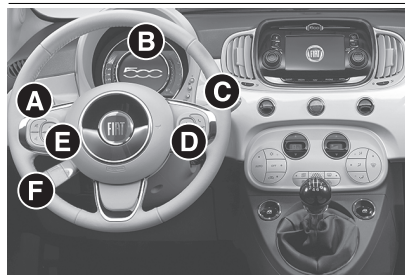

1

F0S0726

- (A) LEFT STALK (External lights)
- (B) DISPLAY
- (C) RIGHT STALK (Windscreen wiper and rear window wiper)
- (D) STEERING WHEEL CONTROLS:
 - ▲ select previous station/track/call
 - ▼ select next station/track/call
 - ☎ Reject/end call
 - ☎ Accept call
- (E) STEERING WHEEL CONTROLS:
 - 🔇 Mute function
 - 🗣 Turn voice command on/off
 - +/- Increase/decrease volume
- (F) CRUISE CONTROL AND SPEED LIMITER CONTROLS

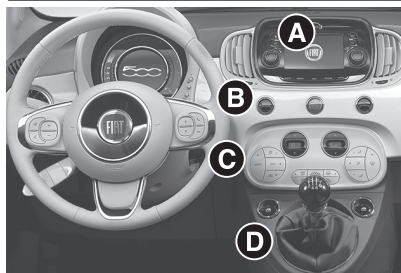

2

F0S0722





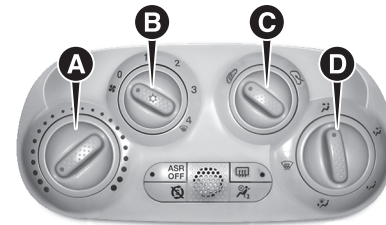

- (A) **Uconnect™**
- (B) FOG LIGHT/REAR FOG LIGHT, HAZARD WARNING LIGHTS, DUAL-DRIVE ELECTRIC POWER STEERING (CITY)
- (C) AIR CONDITIONING, ASR ON/OFF BUTTONS, HEATED REAR WINDOW, START&STOP, PASSENGER AIRBAG WARNING LIGHT
- (D) DRIVER/PASSENGER ELECTRIC WINDOWS, MANUAL/DUALOGIC TRANSMISSION

MANUAL CLIMATE CONTROL SYSTEM



3

F0S0724

- (A) Swivel ring for air mix temperature setting (red = hot, blue = cold)
- (B) Fan activation/setting knob (0 = off, 1-2-3- = ventilation speed, 4 = maximum speed)
- (C) Recirculation on  or off  knob
- (D) Swivel ring for air distribution setting
 -  face
 -  face and feet
 -  feet
 -  windscreen and feet
 -  windscreen

AUTOMATIC CLIMATE CONTROL SYSTEM

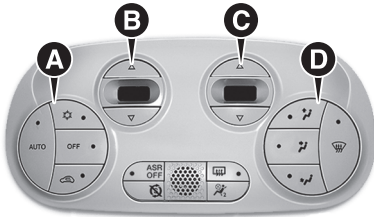

4

FOS0725

- (A) **AUTO** automatic climate control system on/off
 - ☀ Windscreen heater
- OFF** Climate control system off
 - ↻ Recirculation on/off
- (B) Adjustment of temperature inside the passenger compartment.
- (C) Fan speed adjustment
- (D) 🌬 Fast front window demisting/defrosting on/off.
 - 🌬 Air to the windscreen
 - 🌬 Air to the face
 - 🌬 Air to the feet

MULTIFUNCTION DISPLAY

Except for the 1.0 FireFly version:

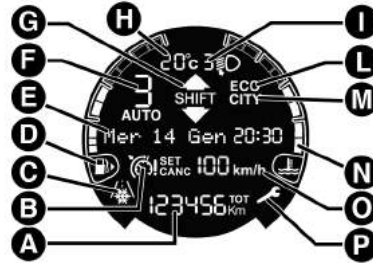

5

FOS0655

- (A) Trip meter (display of distance travelled in kilometres/miles)
- (B) Cruise Control/Speed Limiter
- (C) Warning of possible ice on the road
- (D) Digital fuel level gauge
- (E) Date and time
- (F) Engaged gear indication (Duallogic transmission versions only)
- (G) Gear Shift Indicator
- (H) External temperature gauge
- (I) Headlight alignment position (with dipped beam headlights on only)
- (L) ECO driving mode indication
- (M) Dualdrive electric power steering on

- (N) Digital engine coolant temperature gauge
- (O) Speed Limiter set speed
- (P) Car service indicator

For 1.0 FireFly version:

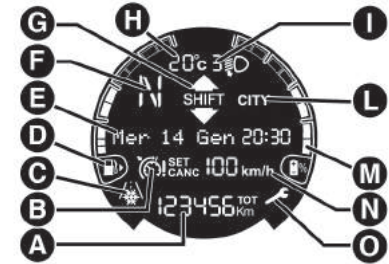

6

FOS0689

- (A) Trip meter (display of distance travelled in kilometres/miles)
- (B) Cruise Control/Speed Limiter
- (C) Warning of possible ice on the road
- (D) Digital fuel level gauge
- (E) Date and time
- (F) Gear shift advice
- (G) Gear Shift Indicator
- (H) External temperature gauge
- (I) Headlight alignment position (with dipped beam headlights on only)
- (L) Dualdrive electric steering on
- (M) Auxiliary battery charge level indicator

- (N) Speed Limiter set speed
- (O) Car maintenance indicator (service)

COLOUR DISPLAY

Except for the 1.0 FireFly version:



7

F0S0551

- (A) Trip meter (display of distance travelled in kilometres/miles)
- (B) Digital engine coolant temperature indicator
- (C) Digital rev counter (tachometer)
- (D) Gear Shift Indicator
- (E) Date
- (F) Outside temperature gauge
- (G) Dualdrive electric power steering on
- (H) Car speed indication
- (I) Headlight alignment position (with dipped beam headlights on only)
- (L) Clock

- (M) Eco Index
- (N) Digital fuel level gauge
- (O) Indication of engaged gear (Dualogic transmission versions only)

For 1.0 FireFly version:



8

F0S0690

- (A) Trip meter (display of distance travelled in kilometres/miles)
- (B) Digital engine coolant temperature indicator
- (C) Digital rev counter (tachometer)
- (D) Start&Stop system (with engine off) / GSI advice to shift to a higher gear (▲^{SHIFT}) or lower gear (▼^{SHIFT}) (while driving with the engine running)
- (E) Date
- (F) Outside temperature gauge
- (G) Dualdrive electric power steering on
- (H) Car speed indication

- (I) Headlight alignment position (with dipped beam headlights on only)
- (L) Clock
- (M) Eco Index
- (N) Digital fuel level gauge
- (O) Suggested gear to be engaged with engine off (see "Advice to shift to neutral gear (N)" paragraph)

HYBRID SYSTEM SCREENS

(for versions/markets, where provided)

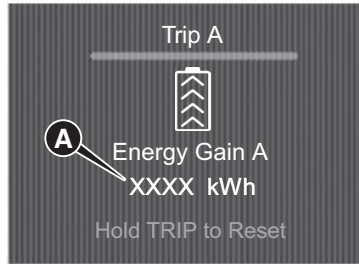

9

F0S0684

Energy recovery (Trip A / Trip B): fig. 9 this shows the cumulative energy (A) recovered during car deceleration (with a gear engaged), used to recharge the auxiliary battery.

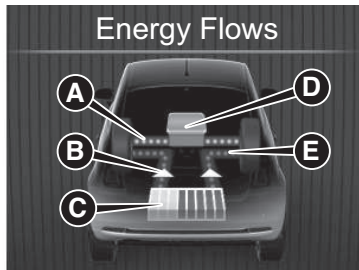

10

F0S0679

Energy flows fig. 10: this indicates the hybrid system usage mode in real time, in the central zone (A), by showing the energy flow to and from the auxiliary battery and electric motor in different colours.

- Running with heat engine only: flows (A) from the heat engine (D) to the wheels.
- Auxiliary battery charge: flows (E) from the wheels to the auxiliary battery (C). The arrows (B) indicate the flow direction
- Assistance from the electric motor to the heat engine: flows (E) from the auxiliary battery (C) to the heat engine.

Energy consumption: The auxiliary battery charge level is indicated by set of 8 green bars (C) fig. 10.

When the battery charge state is below 10%, the last bar remains on but is yellow. Some hybrid system functions may be disabled in these conditions.

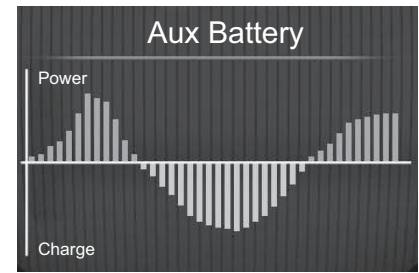

11

F0S0680

Auxiliary battery: The diagram fig. 11 gives a real-time view of the power provided by the auxiliary battery during acceleration (light blue bars) and the power accumulated during deceleration (green bars, the brightness of which is proportional to how flat the battery is and may vary with the battery temperature condition).

WARNING LIGHTS AND MESSAGES









WARNING The instrument panel warning lights/symbols are accompanied by a dedicated message and/or acoustic warning (where provided). These indications are indicative and precautionary and as such must not be considered as exhaustive and/or alternative to the information contained in the online Owner Handbook, which you are advised to read carefully in all cases.









Always refer to the information in this section in the event of a failure indication.

WARNING Causes of ignition and actions to be taken are illustrated in detail in the online Owner Handbook. However, the following actions are briefly outlined in this Quick Guide:

- (*) Contact a Fiat Dealership
- (**) Repair immediately using the dedicated "Fix & Go" kit and contact a Fiat Dealership as soon as possible.







RED WARNING LIGHTS/ SYMBOLES











Warning Light/ Symbol	Meaning
	SEAT BELTS REMINDER
 red	EBD FAILURE (*)
 yellow	
 yellow (Versions with multifunction display)	
 yellow (Versions with colour display)	
	CONVENTIONAL (LEAD) BATTERY NOT SUFFICIENTLY CHARGED / HYBRID SYSTEM FAILURE (*)
	AIRBAG FAILURE (*)
	LOW BRAKE FLUID(*) / HANDBRAKE ENGAGED









Warning Light/ Symbol	Meaning
	ENGINE OIL PRESSURE LOW (*)
	COOLANT TEMPERATURE TOO HIGH (*)
	"DUALOGIC" TRANSMISSION FAILURE (*)
	"DUALDRIVE" ELECTRIC POWER STEERING FAILURE (*)
	OPEN DOORS / BONNET / BOOT (versions with multifunctional display)
  	OPEN DOORS / BONNET / BOOT (versions with colour display)
	SPEED LIMIT EXCEEDED (for versions with colour display)

AMBER WARNING LIGHTS/SYMBOLS

Warning Light/ Symbol	Meaning
	BRAKE PAD WEAR (*)

Warning Light/Symbol	Meaning
 yellow (Versions with multifunction display) ESC yellow (Versions with colour display)	ESC SYSTEM ESC system activation ESC system failure (*) Hill Holder failure (*)
	INJECTION / EOBD SYSTEM FAILURE (*)
	FIAT CODE SYSTEM FAILURE (*)
	FUEL RESERVE - LIMITED RANGE
	REAR FOG LIGHT
	ABS FAILURE (*)
	GENERAL MALFUNCTION INDICATOR (*) (Engine oil pressure sensor failure, Fuel cut-off system intervention/failure, External light failure, Parking sensor failure, Start&Stop system failure, Airbag warning light failure, Rain sensor failure, Dusk sensor failure)

Warning Light/Symbol	Meaning
	START&STOP SYSTEM ON
	START&STOP SYSTEM OFF
	iTPMS Low tyre pressure iTPMS failure/ /ITPMS temporarily deactivated (*)
	ENGINE OIL DEGRADED (*)
	AUXILIARY (DRIVE) BATTERY FAILURE (versions with colour display) / HYBRID SYSTEM FAILURE (*)
	POSSIBLE ICE ON ROAD
	PARKING SENSOR FAILURE (versions with colour display) (*)
	START&STOP SYSTEM FAILURE / HYBRID SYSTEM FAILURE (*)
	SERVICE (SCHEDULED SERVICING) EXPIRED (*)
	ASR SYSTEM OFF (versions with colour display)
	HILL HOLDER FAILURE (versions with colour display) (*)

Warning Light/Symbol	Meaning
	FUEL CUT-OFF SYSTEM (versions with colour display)
	FUEL CUT-OFF SYSTEM FAILURE (versions with colour display)
	PASSENGER AIRBAG/SIDE BAGS DEACTIVATED
	EXTERNAL LIGHT FAILURE (versions with colour display) (*)
	BRAKE LIGHTS FAILURE (versions with colour display) (*)
	RAIN SENSOR FAILURE (*)
	DUSK SENSOR FAILURE (*)
	SPEED LIMITER FAILURE (*)
	FUEL RESERVE - LIMITED RANGE

GREEN WARNING LIGHTS/SYMBOLS

Warning Light/Symbol	Meaning
	SIDE LIGHTS AND DIPPED BEAM HEADLIGHTS/ FOLLOW ME HOME
	FOG LIGHTS
	LEFT DIRECTION INDICATOR
	RIGHT DIRECTION INDICATOR

BLUE WARNING LIGHTS/SYMBOLS

Warning Light/Symbol	Meaning
	MAIN BEAM HEADLIGHTS

WHITE WARNING LIGHTS/SYMBOLS

Warning Light/Symbol	Meaning
	ENERGY RECOVERY (for multifunction display only)

MESSAGES

Message	Meaning
CITY	“DUALDRIVE” ELECTRIC POWER STEERING SYSTEM ACTIVATION
ECO	TURNING ON THE ECO FUNCTION

Furthermore, messages related to the Dualogic transmission may be displayed.

THE KEYS



ATTENTION

1) Do not swallow the battery. Danger of chemical burns. The keys contain a small battery. If the battery is swallowed, it can cause severe internal burns in just 2 hours and cause death. Keep new and used batteries out of the reach of children. If the battery compartment does not close securely, discontinue use of the product and keep it out of reach of children. If you believe that batteries may have been swallowed or inserted inside the body, seek medical attention immediately.

DUALOGIC TRANSMISSION

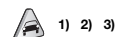

12

F0S0576

MANUAL MODE

Proceed as follows:

- press the brake pedal;
- start the engine;
- push gear lever (A) fig. 12 towards (+) to engage first gear (if starting from N or R, simply place the lever in the middle position) or R to engage reverse;
- release the brake pedal and press the accelerator pedal;
- in driving conditions, push lever (A of the transmission towards (+) to engage the next gear up or towards (-) to engage the next gear down.

AUTOMATIC LOGIC (AUTO)

Proceed as follows:

- ❑ press the brake pedal;
- ❑ start the engine;
- ❑ push the gear lever to A/M to engage automatic mode or to R to engage reverse gear;
- ❑ release the brake pedal and press the accelerator pedal.

ECO FUNCTION

The ECO function can only be activated with automatic mode on. To switch this function on, press the button (E) fig. 12 located on the transmission trim.



WARNING

- 1) Avoid keeping your hand on this lever except during gear change or AUTO/MANUAL mode requests.
- 2) If the transmission is faulty, contact a Fiat Dealership as soon as possible to have the system checked.
- 3) Using the paddles incorrectly (paddles pushed towards the dashboard) could break them.

EXTERNAL LIGHTS



13

F0S0791



14

F0S0792

DAYTIME RUNNING LIGHTS (DRL)



For cars without AUTO function: With the ignition key turned to MAR and the ring turned to position O fig. 13 or fig. 14 (for markets/versions where provided) the daytime running lights are automatically activated; the other lights and interior lighting remain off.

For cars with AUTO function: automatic lighting with the ring turned to AUTO.



DIPPED BEAM HEADLIGHTS/SIDE LIGHTS

With the ignition key in the MAR position and ring in position  fig. 13 or fig. 14 (for markets/versions where provided). The daytime running lights are switched off and the side lights and dipped headlights are switched on.

The  warning light switches on in the instrument panel.

With the ring in the AUTO position, the side lights and the dipped beam headlights are switched on automatically.

MAIN BEAM HEADLIGHTS

With ring in position , push the stalk forward toward the dashboard (stable position). The warning light  switches on.

For cars with the AUTO function: with the ring in the AUTO position and the dipped beam headlights on, push the stalk forwards toward the dashboard.

The main beam headlights are switched off by pulling the stalk towards the steering wheel.

FLASHING THE HEADLIGHTS

Pull the stalk toward the steering wheel and release it.

PARKING LIGHTS

These lights can be turned on with the ignition switch in the STOP position or with the key removed, by moving the left stalk ring first to the O position (or the AUTO position if the vehicle does not have a dusk sensor) and then to position .

The  warning light switches on in the instrument panel. Repeat the same operation to switch them off.

AUTO FUNCTION

(for versions/markets, where provided)

Function activation

Turn the left stalk ring (A) fig. 15 or fig. 16 (for markets/version where provided) to the AUTO position.

IMPORTANT The function can only be activated with the ignition device in the MAR position.

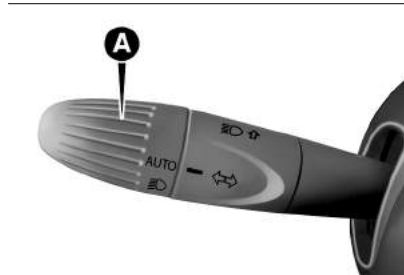

15

F0S0610

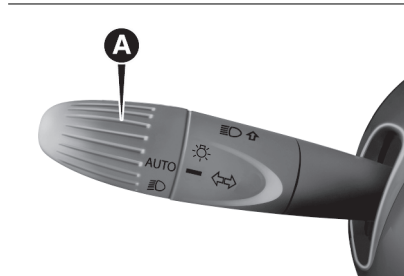

16

F0S0790

Function deactivation

To deactivate the function, turn the left stalk ring (A) to position .

DIRECTION INDICATORS

Move the stalk up or down to activate the left or right direction indicator.

FOG LIGHTS/REAR FOG LIGHTS

(for versions/markets, where provided)

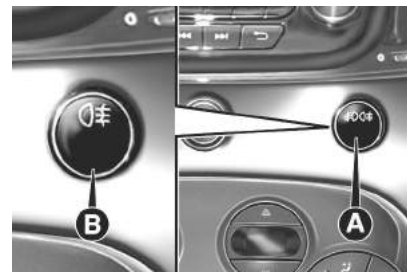

Only with dipped beams on.

Press button (A) fig. 17.



17

F0S0568

- first press: turns on the fog lights, the  warning light on the instrument panel will turn on;
- second press: turns on the rear fog lights, the  warning light on the instrument panel will turn on;
- third press: front/rear fog lights off. If there are no fog lights, press button (B) to turn the rear fog light on/off.



IMPORTANT

2) *The daytime running lights are an alternative to the dipped headlights for driving during the daytime in countries where it is compulsory to have lights on during the day; where it is not compulsory, the use of daytime running lights is permitted.*

3) *Daytime running lights cannot replace dipped beam headlights when driving at night or through tunnels. The use of daytime running lights is governed by the highway code of the country in which you are driving. Comply with legal requirements.*

MOPAR® CONNECT

(where provided)

These services let you keep your car under control at all times and receive assistance in the event of accident, theft or breakdown.

Availability of the services depends on the country (list available on the www.driveuconnect.eu website). Request activation by following the instructions received at the email address given when your car was handed over to you.

SERVICES

According on the equipment of the car and of the country, different services may be available for different durations. For further information about your car, go to the personal page on the official Fiat website.

Some of the packages made available to the customer are:

- my:Assistant: customer assistance in the event of an accident, breakdown or attempted theft. The package can be accessed from the **Uconnect™ LIVE** app and can also be used to detect unauthorised towing or tampering of the car

- my:RemoteControl
- my:Car
- my:Journey

Download the **Uconnect™ LIVE** app for smartphones or access the www.driveuconnect.eu portal to use the connected services.

You can find all the details about the services in the **Mopar® Connect** section of the www.driveuconnect.eu portal.

The main functions of the my:RemoteControl, my:Car and my:Journey packages (where available) can be run using Google Assistant voice commands (where provided), in addition to the **Uconnect™ LIVE** app and the web portal www.driveuconnect.eu.

With Mobility Services, it is also possible to take advantage of proposals from FCA partners.

CHILD RESTRAINT SYSTEMS

⚠ 4) 5) 6) 7) 8) 9) 10) 11) 12)

For optimal protection in the event of an impact, all occupants must be seated and wearing adequate restraint systems, including newborn and other children! This prescription is compulsory in all EC countries according to EC Directive 2003/20/EC.

PASSENGER'S FRONT AIRBAG AND CHILD RESTRAINT SYSTEMS

Rearward facing child restraint systems must NEVER be fitted on the front seat with an active passenger side bag since in the event of an impact the airbag activation may cause fatal injuries to the transported child.

ALWAYS comply with the instructions on the label stuck on the passenger side sun visor fig. 18.



18

F0S0502

DEACTIVATING THE PASSENGER SIDE AIRBAGS: FRONT AIRBAG AND FRONT SIDE BAG

(for versions/markets, where provided)

Warning light (A) fig. 19 in the centre of the dashboard will stay on constantly until the passenger's airbag and the front side bag are reactivated (for versions/markets, where provided).

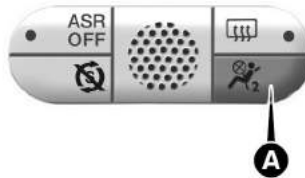

19

F0S0389

WARNING To manually deactivate the passenger side front airbag and the front side bag (for versions/markets, where provided), see paragraph "Display" in the "Knowing the instrument panel" chapter.



IMPORTANT

4) SEVERE DANGER! When a front passenger airbag is active, do not install rearward facing child restraint systems on the front passenger seat. Deployment of the airbag in a crash could cause fatal injuries to the child regardless of the severity of the collision. It is advisable to always carry children in a child restraint system on the rear seat, which is the most protected position in the event of a collision.



5) The sun visor bears a label with suitable symbols reminding the user that it is compulsory to deactivate the airbag if a rearward facing child restraint system is fitted. Always comply with the instructions on the passenger side sun visor (see the "Supplementary Restraint System (SRS) - Airbag" paragraph).



6) Should it be necessary to carry a child on the passenger side front seat in a rear facing child restraint system, the passenger side front and side airbags must be deactivated through the display main menu, verifying deactivation by checking that the warning light  located in the central part of the dashboard has switched on. Move the passenger's seat as far back as possible to avoid contact between the child seat and the dashboard.

7) Do not move the front or rear seat if a child is seated on it or on the dedicated child restraint system.

8) When an active passenger airbag is fitted, DO NOT install rear facing child restraint systems on the front seat. Deployment of the airbag in a crash could cause fatal injuries to the child regardless of the severity of the collision.

9) When there is an active passenger airbag, DO NOT install rearward facing child restraint systems on the front seat. Deployment of the airbag in a crash could cause fatal injuries to the child regardless of the severity of the collision. It is advisable to always carry children in a child restraint system on the rear seat, which is the most protected position in the event of a collision.

10) In some versions, in case of LED failure  (located on the plate of the dashboard), the warning light  on the console turns on and the passenger side airbags are deactivated.

11) The  warning light indicates the passenger airbag protection status. If the warning light is off, passenger side protection is active: to deactivate it, use the Setup Menu (in this case the LED lights up). When the car is started (ignition key turned to MAR position), the warning light turns on for about 8 seconds, provided that at least 5 seconds have elapsed from when it was switched off. If not, contact a Fiat Dealership. If the engine is switched off/on again in less than 5 seconds the warning light may remain off. In this case, to check correct warning light operation, switch the engine off, wait for at least 5 seconds and switch the engine on again. The warning light may light up with various intensity levels depending on the car conditions. The intensity may also vary during the same key cycle. When the ignition key is turned to MAR, the  warning light switches for few seconds, then if the passenger airbag is active it should switch off.

12) If a child must be carried on the front seat in a rearward facing child restraint system, it is compulsory to deactivate the passenger side front airbag, making sure that it is deactivated by checking the dedicated warning light on the instrument panel. Move the passenger's seat as far back as possible to avoid contact between the child restraint system and the dashboard.

iTPMS (indirect Tyre Pressure Monitoring System)

 13) 14) 15) 16) 17) 18)

The car can be equipped with the iTPMS (indirect Tyre Pressure Monitoring System) which monitors the tyre inflation status.

To access the iTPMS screens press the TRIP button.

Correct tyre inflation pressure (version with colour display): If the pressure of all the tyres corresponds to the correct value, the display shows the fig. 20 screen.



20

F0S0496

Low tyre pressure: The system warns the driver if one or more tyres are flat by switching on the warning light on the instrument panel. Furthermore, the display will show “KO” beside the tyres along with a warning message.



IMPORTANT

13) If the system signals a pressure drop on one or more tyres, it is recommended to always check the pressure on all tyres.

14) The iTPMS does not relieve the driver from the obligation to check the tyre pressure every month; it is not to be considered a system to replace servicing or a safety system.

15) Tyre pressure must be checked with tyres cold. Should it become necessary for whatever reason to check pressure with warm tyres, do not reduce pressure even though it is higher than the prescribed value, but repeat the check when tyres are cold.

16) The iTPMS cannot indicate sudden tyre pressure drops (for example when a tyre bursts). In this case, stop the car, braking with caution and avoiding abrupt steering.

17) The system only warns that the tyre pressure is low: it is not able to inflate them.

18) Insufficient tyre inflation increases fuel consumption, reduces the tread duration and may affect the capacity to drive safely.

CHANGING A WHEEL

CHANGING PROCEDURE



19) 20) 21) 22) 23) 24) 25) 26) 27)

- Stop the car in a position that is not dangerous for oncoming traffic where you can change the wheel safely. The ground must be flat and sufficiently compact;
- stop the engine and engage the parking brake;
- engage first gear or reverse;
- wear the reflective safety jacket (compulsory by law) before getting out of the car. In any case, follow the road safety laws in force in the country where you are driving;
- raise the mat on the floor of the luggage compartment;
- loosen the locking device (B) fig. 21;
- take out the tool bag (C) fig. 21 and place it next to the wheel to be changed;
- take the space-saver wheel (D) fig. 21;

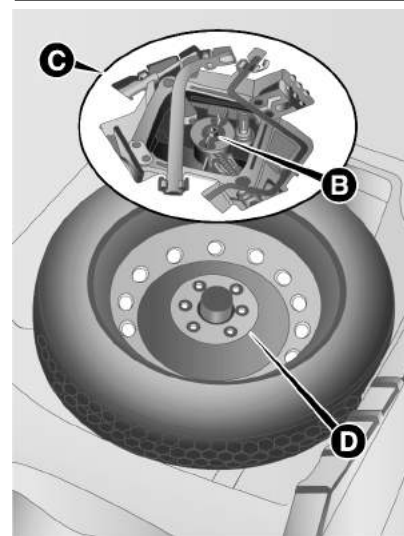

21

F0S0127

- for cars with wheel cap: use the screwdriver provided, applying leverage to the dedicated opening on the outer edge;
- for cars equipped with 15" steel wheels with aesthetic hub caps: take the extractor (A) fig. 22 from the Quick Guide compartment;

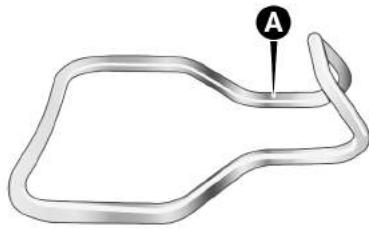

22

FOS0671

- ❑ Hold the extractor with two fingers, insert the tab between tyre and hubcap (B) fig. 23 and pull towards yourself, perpendicularly to the wheel;

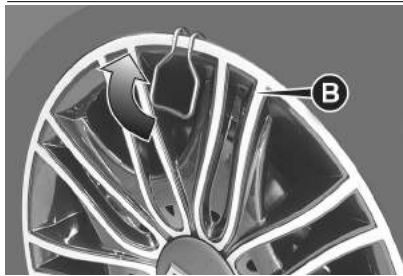

23

FOS0670

- ❑ for cars fitted with alloy wheels: remove the press-fitted hub cap using the screwdriver provided;

- ❑ loosen the retaining bolts for the wheel to be changed by about one turn using the spanner provided;
- ❑ if the car is equipped with side skirts, to let the jack pass under the car, the latter must be tilted (as shown in fig. 24);

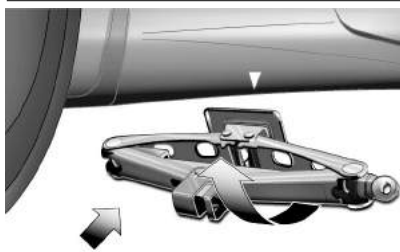

24

FOS0328



- ❑ turn the jack handle to partially open it;
- ❑ position the jack near the wheel to be repaired at the reference point ▽ on the side member fig. 24;
- ❑ make sure that the jack is positioned correctly;

- ❑ alert any bystander that the car is about to be raised; all persons should be kept away from the car and nobody must touch it until it has been lowered;
- ❑ fit the handle to operate the jack and raise the car until the wheel is a few centimetres above the ground. When turning the jack handle, make sure that it can turn freely without scraping your hand against the ground. The moving components of the jack (screws and joints) can also cause injuries: avoid touching them. If you come into contact with lubricating grease, clean yourself thoroughly;
- ❑ loosen the bolts completely and remove the wheel to be replaced;
- ❑ make sure the contact surfaces between space-saver wheel and hub are clean so that the fastening bolts will not come loose;
- ❑ fit the space-saver wheel aligning the pin with one of the holes on the wheel;

- screw in the 4 fastening bolts;
- turn the jack handle to lower the car and remove the jack;
- fasten the bolts completely, passing alternately from one bolt to the opposite one.



IMPORTANT

19) *The space-saver wheel (for versions/markets where provided) is specific to your car, do not use it on other models, nor use the space-saver wheel of other models on your car. The space-saver wheel must only be used in the event of an emergency. Never use it for more than strictly necessary and never exceed a speed of 80 km/h.*

20) *On the space-saver wheel there is an orange sticker, summarising the main warnings regarding space-saver wheel usage restrictions. Never remove or cover the label. The label contains the following indications in four languages: "Important! For temporary use only! 80 km/h max.! Replace with standard wheel as soon as possible. Do not cover this label in use." Never apply a hubcap on a space-saver wheel.*

21) *If you change the type of wheel (alloy rims instead of steel rims and vice versa) you will have to change the entire set of fastening bolts with another set of suitably sized bolts.*

22) *Alert other drivers that the car is stationary in compliance with local regulations: hazard warning lights, warning triangle, etc. Any passengers on board should leave the car, especially if it is heavily laden. Passengers should stay away from on-coming traffic while the wheel is being changed. On a gradient or uneven road, use chocks or appropriate objects to block the wheels of the car*

23) *The driving features of the car may change when a space-saver wheel is fitted. Avoid violent acceleration and braking, abrupt steering and fast cornering. The total life of a space-saver spare wheel is approximately 3,000 km, after which it must be replaced by another wheel of the same type. Never install a traditional tyre on a rim designed to be used as a space-saver wheel. Have the wheel repaired and refitted as soon as possible. Using two or more space-saver wheels at the same time is forbidden. Do not apply grease to the bolt threads before fitting: they could come unscrewed.*

24) *The jack is a tool developed and designed only for changing a wheel, if a tyre gets punctured or damaged, on the car with which it is supplied or on other cars of the same model. It must not be used, for example, to jack other vehicle models or objects. Never use it to carry out servicing or repairs under the vehicle or to change summer/winter wheels and vice versa: we advise you to contact a Fiat Dealership. Never go under the raised vehicle: use it only in the positions indicated. Do not use the jack for loads higher than the one shown on its label. Never start the engine with car raised. If the car is raised more than necessary, everything can become more unstable, with the risk of the car dropping violently. Thus, lift the car only as needed in order to access the spare wheel.*

25) *Snow chains cannot be fitted to the space-saver wheel. So, if a front (drive) wheel is punctured and chains are needed, a rear wheel should be fitted to the front of the car and the space-saver wheel should be fitted to the rear. In this way, equipped with two normal drive wheels at the front, they can be fitted with snow chains, thus resolving the emergency situation.*

26) *Incorrectly fitting the hubcap may cause it to fall off when the car is in motion. Never tamper with the inflation valve. Never introduce tools of any kind between rim and tyre. Check tyre and space-saver wheel pressures regularly, complying with the values given in the "Wheels" chapter in this guide.*

27) *It is extremely dangerous to attempt to change a wheel on the side of the car next to the driving lane: make sure that the car is at a sufficient distance from the road, to avoid being run over.*



WARNING

4) *When turning the jack handle make sure that it can turn freely without scraping your hand against the ground. The moving components of the jack ("worm screw" and joints) can also cause injuries: avoid touching them. If you come into contact with lubricating grease, clean yourself thoroughly.*

FIX & GO KIT

(for versions/markets, where provided)

The Fix&Go quick tyre repair kit is located in the boot inside a dedicated container.

⚠ 28) 29) 30)

⚠ 5)

TYRE REPAIR PROCEDURE

Preliminary operations:

- Stop the car in a position that is not dangerous for oncoming traffic where you can change the wheel safely. The ground must be flat and sufficiently compact;
- stop the engine and engage the parking brake;
- engage 1st gear if the car is uphill, or reverse if the car downhill;
- steer the wheels completely;
- in the event of a steep slope, place a wedge or stone behind the wheels;
- Wear the reflective safety jacket (compulsory by law) before getting out of the car. In any case, follow the road safety laws in force in the country where you are driving;
- wear the gloves.

Tyre repair:

Remove the adhesive speed label (3) fig. 25 and fig. 28 and apply it in a clearly visible position on the dashboard

OPT1 kit

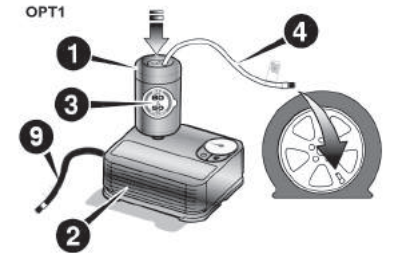

25

F0S2074

- remove the cap from the tyre valve and connect and screw the transparent tube of the sealing fluid (4) fig. 25 onto the valve. If a 250 ml cartridge is present the housing of the transparent tube is provided with removable ring to facilitate extraction. Make sure that the ON-OFF button (5) fig. 28 is in the off position (button not pressed);

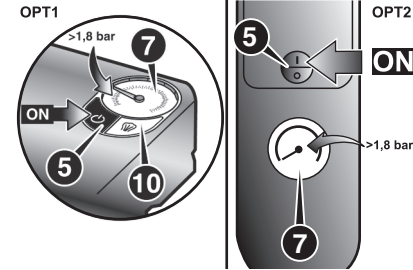

26

F0S1395

- plug the electrical connector of the tyre inflation kit into the 12V socket of the car and start the engine;

- ❑ operate the compressor by pressing the ON/OFF button (5) fig. 26.

When the pressure gauge (7) indicates the prescribed pressure indicated in the "Wheels" chapter in this Quick Guide or on the label, switch off the compressor by pressing the button again and in any case do not disconnect the hose until the sealing liquid has been blown in (about 2 minutes);

- ❑ If the pressure gauge (7) fig. 26 reads a pressure lower than 1.8 bar / 26 psi 15 min. after turning on the compressor, switch off the compressor, disconnect the sealant hose (4) fig. 25 from the tyre valve proceed with the procedure for restoring pressure after repair described in the following paragraph after having disconnected the cartridge. Disconnect the cartridge (1) from the compressor by pressing the release button (8) and lifting the cartridge (1) upwards fig. 27.

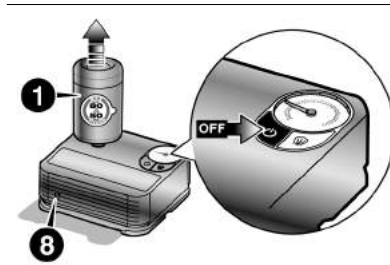

27

P2000161

OPT2 kit

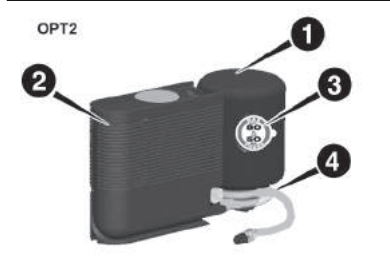

28

FOS2075

Only use in the event of a puncture; do not use to inflate a tyre that has not been punctured.

- ❑ remove the cap from the tyre valve and connect and screw the transparent tube of the sealing fluid (4) fig. 28 onto the valve. Make sure that the ON-OFF button (5) fig. 26 is in the off position (button not pressed);
- ❑ plug the electrical connector of the tyre inflation kit into the 12V socket of the car and start the engine;
- ❑ operate the compressor by pressing the ON/OFF button (5) fig. 26. When the pressure gauge (7) indicates the prescribed pressure indicated in the "Wheels" chapter in this Quick Guide or on the label, switch off the compressor by pressing the button again and in any case do not disconnect the hose until the sealing liquid has been blown in (about 2 minutes);

- ❑ If the pressure gauge (7) fig. 26 reads a pressure lower than 1.8 bar / 26 psi 15 min. after turning on the compressor, switch off the compressor, disconnect the sealant hose (4) fig. 28 from the tyre valve proceed with the procedure for restoring pressure after repair described in the following paragraph.

Procedure for restoring pressure after repair

- ❑ Move the vehicle approximately 10 m to distribute the sealant;
- ❑ secure the car following the instructions described in the "Preliminary operations" paragraph in this chapter;
- ❑ restore the pressure using the black inflation tube (9) fig. 25 for the **OPT1** version or the inflation tube (4) fig. 28 for the **OPT2** version until the prescribed pressure is reached. If also in this case, the pressure is lower than 1.8 bar / 26 psi 15 minutes after turning on, do not resume driving but contact a Fiat Dealership.

Only for OPT1: Press the air release button to adjust any tyre overpressure (10) fig. 26.

After driving for approximately 8 km/ 5 miles, repeat the procedure for restoring the pressure.

For OPT2 only: This can only be used to restore pressure after using the kit to repair a puncture (i.e. with empty sealing cartridge)



IMPORTANT

28) *The information required by the applicable regulation is indicated on the Fix&Go kit package label. Carefully read the cartridge label before use and avoid improper use. The kit should be used by adults and cannot be used by children.*

29) IMPORTANT: *Do not exceed 80 km/h. Avoid sudden acceleration or braking. The kit provides a temporary repair; therefore the tyre must be examined and repaired by a specialist as soon as possible. Before using the kit, ensure that the tyre isn't excessively damaged and that the rim is in good condition, otherwise do not use it and call roadside assistance. Do not remove foreign bodies from the tyre. Do not let the compressor turned on for more than 20 consecutive minutes - overheating hazard.*

30) *The compressor in the kit **MAY NOT BE USED** for any purpose other than tyre repair.*



WARNING

5) The sealant fluid is effective with external temperatures from -40°C to +50°C. The sealant fluid has an expiry date and must be replaced periodically. It is possible to repair tyres with damage on the tread up to a maximum diameter of 6 mm. Show the cartridge and the label to the personnel who will handle the tyre treated with the Fix&Go kit.

REPLACING A BULB

! 31) 32) 33) 34)

! 6) 7) 8)

FRONT LIGHT CLUSTERS

Front direction indicators (A), dipped beam (B)

POP versions only:

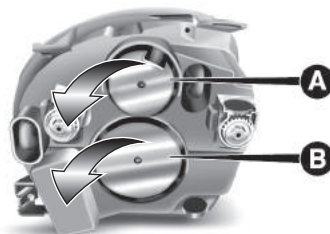

29

FOS0732

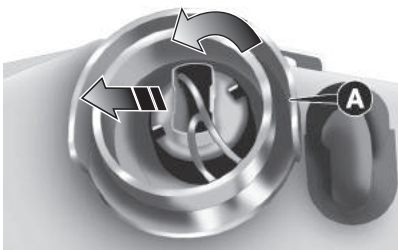

30

FOS0735

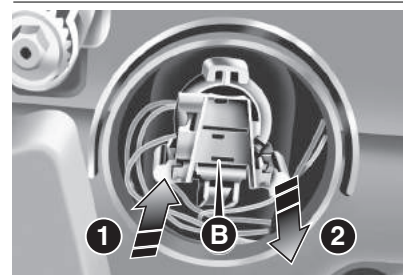

31

FOS0734

Excluding POP versions:

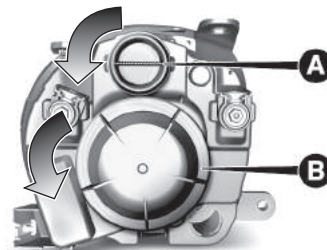

32

FOS0733

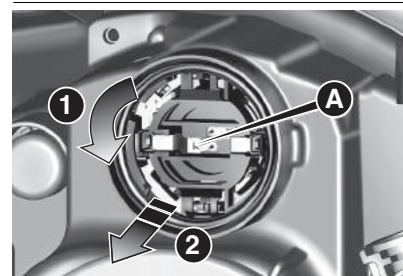

33

FOS0736

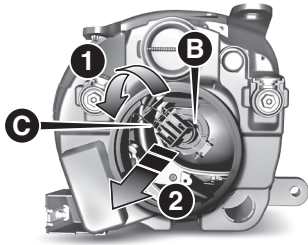

34

F0S0737

Before extracting the lamp, disconnect the connector and release the bulb holder catch (C).

Dipped beam headlights with gas discharge bulbs (Xenon)

(for versions/markets, where provided)



For replacement, contact a Fiat Dealership.

Tail light/daytime running lights (C), main beam headlight (D) fig. 36

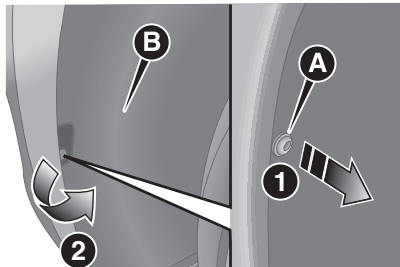

35

F0S0748

(A) Cover fixing screws (series)

(B) Coverage

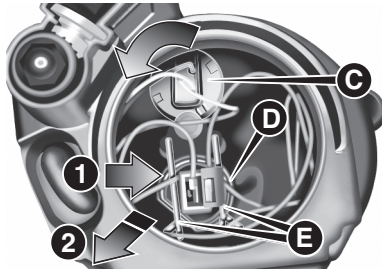

36

F0S0738

(1) Release the bulb holder clip (E).

Side direction indicators

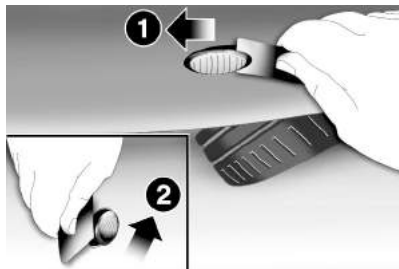

37

F0S0355

Fog lights

To replace a fog light, contact a Fiat Dealership.

REAR LIGHT CLUSTER

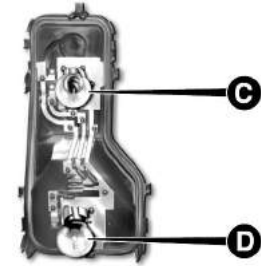

38

F0S0580

(C) Tail / brake light

(D) Direction indicators

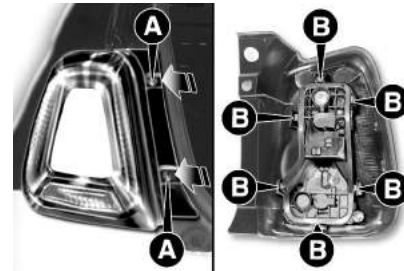

39

F0S0579

- undo the two fixing screws (A);
- release the locking tabs (B)

Reversing light/rear fog light

Access through the underside of the rear bumper fig. 40

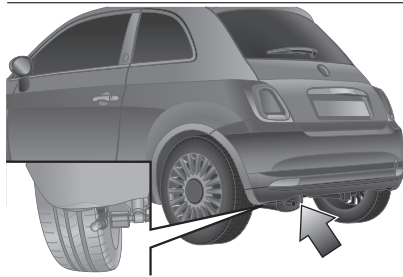

40

F0S0674

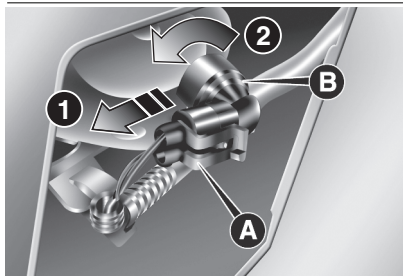

41

F0S0741

(A) Electrical connector

(B) Bulb holder

Third brake lights

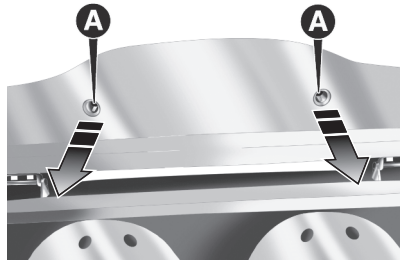

42

F0S0742

(A) Fixing screws



43

F0S0743

(B) Electrical connector

(C) Retaining device

Number plate lights

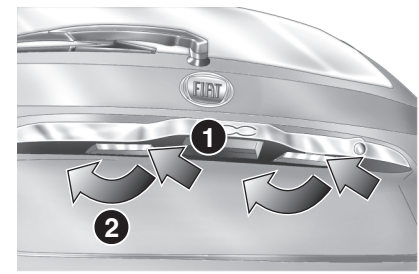

44

F0S0744



IMPORTANT

31) Modifications or repairs to the electric system that are not carried out properly or do not take the system technical specifications into account can cause malfunctions leading to the risk of fire.

32) Halogen bulbs contain pressurised gas, in the case of breakage they may burst causing glass fragments to be projected outwards.

33) Only replace the light bulbs when the engine is off and in a position that does not interfere with traffic and lets you safely replace them (see the description in the "Replacement" paragraph). Also ensure that the engine is cold, to prevent the risk of burns.

34) Before replacing the bulb, wait for the exhaust ducts to cool down: **DANGER OF SCALDING!**

35) Due to the high power supply voltage, gas discharge bulbs (Xenon) should only be replaced by specialised personnel: danger of death! Contact a Fiat Dealership.



WARNING

6) Halogen bulbs must be handled holding the metallic part only. Touching the transparent part of the bulb with your fingers may reduce the intensity of the emitted light and even compromise duration of the bulb. In the event of accidental contact, wipe the bulb with a cloth moistened with alcohol and let the bulb dry.

7) Where possible, it is advisable to have bulbs changed at a Fiat Dealership. The correct operation and direction of the external lights are absolutely essential for the safety of the car and of compliance with the law.

8) The intervention must be carried out taking all precautions necessary to avoid damaging the bodywork (please use a sufficiently rigid and appropriately thick plastic card).

FUSES

 36) 37)

 9)



IMPORTANT

36) Replacement of a fuse. All work may be performed only by a Fiat Dealership or a qualified repair workshop. The replacement of a fuse by a third party may cause a serious car fault.

37) Installation of electrical accessories. The car's electrical circuit is designed to function with standard or optional equipment, before installing other electrical equipment or accessories in the vehicle contact a Fiat dealership or a qualified repair workshop.



WARNING

9) FCA shall not be held liable for expenses resulting from car repair or anomalies resulting from the installation of accessories not provided or recommended by Fiat and not installed according to specifications, in particular when the combined consumption of all additional equipment connected exceeds 10 mA.

SCHEDULED SERVICING

SERVICE SCHEDULE

WARNING Once you have carried out the last intervention in the table, continue with the scheduled servicing, maintaining the frequency indicated in the plan by marking each operation with a dot or dedicated note.

Warning: simply restarting the maintenance from the start of the plan may cause the allowed interval to be exceeded for some operations!

Thousands of miles	9	18	27	36	45	54	63	72	81	90
Thousands of kilometres	15	30	45	60	75	90	105	120	135	150
Years	1	2	3	4	5	6	7	8	9	10
Check tyre condition/wear and adjust pressure, if necessary; check the expiry date of the "Fix&Go" repair kit (for versions/markets, where provided)	●	●	●	●	●	●	●	●	●	●
Check operation of lighting system (headlights, direction indicators, hazard warning lights, boot, passenger compartment, glove compartment, instrument panel warning lights, etc.)	●	●	●	●	●	●	●	●	●	●
Check and, if necessary, top up fluid levels (1)	●	●	●	●	●	●	●	●	●	●
Check exhaust emissions/smokiness	●	●	●	●	●	●	●	●	●	●
Use the diagnosis socket to check fuel/engine control systems operation, emissions and engine oil decay (the latter for versions/markets, where provided)	●	●	●	●	●	●	●	●	●	●
Visually inspect the condition of: bodywork, underbody protection, pipes and hoses (exhaust - fuel - brakes), rubber parts (boots, sleeves, bushes, etc.)	●		●		●		●		●	
Check windscreen/rear window wiper blade position/wear (for markets/versions, where provided)	●		●		●		●		●	
Check operation of the windscreen wiper/washer system and adjust nozzles, if necessary	●		●		●		●		●	
Check cleanliness of hood and boot locks, cleanliness and lubrication of linkage	●		●		●		●		●	
Check soft top operation while closing and opening; check of seals and lubrication of canvas sliding side guide (only cabrio versions)	●		●		●		●		●	

Thousands of miles	9	18	27	36	45	54	63	72	81	90
Thousands of kilometres	15	30	45	60	75	90	105	120	135	150
Years	1	2	3	4	5	6	7	8	9	10
Check handbrake lever travel and adjust, if necessary	●		●		●		●		●	
Visually inspect condition and wear of front/rear disc brake pads (for versions/markets, where provided) and operation of pad wear indicator	●	●	●	●	●	●	●	●	●	●
Visually inspect condition and wear of the rear drum brake lining	●	●	●	●	●	●	●	●	●	●
Check the auxiliary drive belt tension, and replace if necessary (for 1.0 FireFly version and dusty roads only) (9)								●		
Visually inspect condition of various drive belt(s) (0.9 TwinAir and 1.2 8V versions) (5)				●						
Visually inspect condition of various drive belts (1.0 FireFly version)	●	●	●	●	●	●	●	●	●	●
Inspect and if necessary adjust tensioning of accessory drive belt(s) (for versions without automatic tensioner only)		●								●
Visually inspect conditions of toothed timing drive belt (0.9 TwinAir versions excluded) (5)				●						
Check and, if necessary, adjust tappet clearance (1.2 8V petrol versions)				●				●		
Check and, if necessary, adjust tappet clearance (LPG versions)		●		●		●		●		●
Check and, if necessary, top up Dualogic transmission electro-hydraulic control oil level (2)		●		●		●		●		●
Visually inspect condition of: LPG pipes and connectors, LPG tank fixing (LPG versions only)		●		●		●		●		●
Check fuel system operation and parameters using the diagnosis socket (LPG versions only)		●		●		●		●		●
Change engine oil and replace oil filter (0.9 TwinAir versions) (3) (O) (●)	O	●	O	●	O	●	O	●	O	●
Change engine oil and oil filter (1.0 FireFly version)	●	●	●	●	●	●	●	●	●	●

Thousands of miles	9	18	27	36	45	54	63	72	81	90
Thousands of kilometres	15	30	45	60	75	90	105	120	135	150
Years	1	2	3	4	5	6	7	8	9	10
Change engine oil and oil filter (1.2 8V 69 HP / 1.2 8V 69 HP LPG versions) (8) (●)	●	●	●	●	●	●	●	●	●	●
Spark plug replacement(4)		●		●		●		●		●
Replace accessory drive belt/s	(5)									
Replace toothed timing drive belt (1.2 8V versions)	(5)									
Replace air cleaner cartridge (6)		●		●		●		●		●
Change the brake fluid	(7)									
Replace filter inside the pressure regulator (LPG versions only)						●				
Replace paper filter (LPG in gaseous state) (LPG versions only)		●		●		●		●		●
Replace passenger compartment filter (6) (○) (●)	○	●	○	●	○	●	○	●	○	●

- (1) Topping up must be carried out with the fluids specified in "Refilling" in this Quick Guide and only after checking that the system is undamaged
- (2) Check to be carried out every year for cars on the road in countries with particularly severe climates (cold countries).
- (3) If the vehicle is used mainly on urban routes or the annual distance travelled is less than 10,000 km, the engine oil and engine oil filter must be changed every year.
- (4) For the 0.9 TwinAir versions, the following are essential to ensure correct operation: only use spark plugs of the same make and type which are specially certified for these engines (see the information in the "Engine" paragraph in the "Technical specifications" chapter); strictly comply with the spark plug replacement interval given in the Scheduled Servicing Plan; for spark plug replacement, it is advisable to contact a Fiat Dealership.
- (5) For versions 0.9 TwinAir and 1.2 8V: the maximum mileage is 120,000 km. The belt must be replaced every 6 years, regardless of distance travelled. If the vehicle is used in heavy conditions (dusty areas, especially severe weather conditions, very low or very high temperatures for extended periods, urban driving, long periods of idling), the maximum mileage is 60,000 km. The belt must be replaced every 4 years regardless of the mileage. For the 1.0 FireFly version: Replace the auxiliary component belt every 240,000 km.

- (6) If the vehicle is used in dusty areas, this filter should be replaced every 15,000 km.
- (7) The brake fluid must be changed every two years, regardless of the mileage.
- (8) If the vehicle is mainly used in towns and cities and does not exceed the mileage shown on the scheduled servicing plan, change the engine oil and filter every year.
- (9) The inspection, and if necessary the replacement, must be performed according to mileage and regardless of the elapsed time.
- (O) Recommended operations
- Mandatory operations

REFILLING

	1.0 FireFly	Prescribed fuels and original lubricants
Fuel tank (petrol - litres):	35	Unleaded petrol with at least 95 R.O.N. (EN228 specifications)
including a reserve of (litres):	5.0	
Engine cooling system (litres):	4.4	50% mixture of distilled water and PARAFLU ^{UP} (*)
Engine sump (litres):	2.2	SELENIA ECO2
Engine sump and filter (litres):	2.5	SELENIA ECO2
Gearbox/differential casing:	1.65 kg / 1.94 litres	TUTELA TRANSMISSION GEARFORCE
Hydraulic brake circuit (kg):	0.55	TUTELA TOP 4/S
Windscreen and rear window washer fluid reservoir (litres):	2.5	Mixture of water and PETRONAS DURANCE SC35

(*) When the vehicle is used in particularly harsh climate conditions, we recommend using a 60% mixture of PARAFLU^{UP} and 40% demineralised water.

	1.2 8V 69 HP / 1.2 8V 69 HP LPG	0.9 TwinAir 85 HP ^(°)	Prescribed fuels and original lubricants
Fuel tank (petrol - litres):	35 / 30.5 (***)	35	Unleaded petrol with at least 95 R.O.N. (EN228 specifications)
including a reserve of (litres):	5.0	5.0	
Engine cooling system (litres):	4.85 / 5.2 (**)	5.3	50% mixture of distilled water and PARAF ^{LU} UP ^(*)
Engine sump (litres):	–	2.8	SELENIA DIGITEK P.E.
	2.5	–	SELENIA ECO2
Engine sump and filter (litres):	–	3.2	SELENIA DIGITEK P.E.
	2.8	–	SELENIA ECO2
Gearbox/differential casing (litres):	1.65	1.65	TUTELA TRANSMISSION GEARFORCE
Dualogic transmission hydraulic activation system:	0.70 (litres) / 0.59 (kg)	–	TUTELA CS SPEED Special oil with "ATF DEXRON III" type additive
Hydraulic brake circuit (kg):	0.55	0.55	TUTELA TOP 4/S
Hydraulic clutch controls (RH drive versions)	0.100	–	
Windscreen and rear window washer fluid reservoir (litres):	2.5	2.5	Mixture of water and PETRONAS DURANCE SC35

(°) For versions/markets, where provided

(*) When the vehicle is used in particularly harsh climate conditions, we recommend using a 60% mixture of PARAF^{LU}UP^(*) and 40% demineralised water.

(**) LPG versions

(***) LPG versions (including reserve). The figure already takes into account the 80% tank filling limit and the residual fluid required for priming and the maximum permitted capacity. In addition, after different refuelling processes, this figure may vary due to differences between the network pump supply pressures, pumps having different supply/locking features, tank not completely run out of fuel.

UCONNECT™ RADIO



45

F0S0729



- Brief button press: on/off
- Turn knob: volume adjustment



Volume activation/deactivation (Mute/ Pause)



Exit the selection/return to previous screen

BROWSE ENTER

- Brief button press: confirm the option shown on the display
- Turn knob: scroll list or select track

INFO

Display mode selection (Radio, Media Player)

AUDIO

Access to the sound setting and adjustment functions

MENU

Access to the Settings menu

MEDIA

USB source selection

RADIO

Access to the Radio mode

1-2-3-4-5-6

- Long button press: store current radio station
- Short button press: recall stored radio station

A-B-C

Selection of the group of radio presets or selection of the desired letter in each list



- Brief button press: Search for previous radio station or selection of USB previous track
- Long button press: Scan of lower frequencies until released/Fast rewind of USB track



- Brief button press: search for next radio station or selection of USB next track
- Long button press: Scan of higher frequencies until released/Fast forward of USB track



Shuffle USB tracks



USB loop

UCONNECT™ 5" RADIO/NAV



46

F0S0730



- Brief button press: on/off
- Turn knob: volume adjustment



Volume activation/deactivation (Mute/Pause)



Display on/off



Exit the selection/return to previous screen



Settings

BROWSE ENTER

- Brief button press: confirm the option shown on the display
- Turn knob: scroll list or tune to a radio station

APPS

Access to the additional functions, e.g.: Time display, Compass (where applicable), external temperature, Media radio

PHONE

Phone data display

TRIP (Uconnect™ 5" version)

Access to the Trip menu

NAV (Uconnect™ 5" Nav version)

Access to the Navigation menu

MEDIA

Source selection: USB, **Bluetooth®**

RADIO

Access to the Radio mode

CONTROLS ON THE STEERING WHEEL

See the description in the "Car interior" fig. 1 chapter.

PAIRING A MOBILE PHONE

IMPORTANT Only perform this operation with the vehicle stationary and in safe conditions; this function is deactivated when the vehicle is moving. The pairing procedure for a mobile phone is described below: always consult the handbook for the mobile phone in any case.

To pair the mobile phone, proceed as follows:

- activate the **Bluetooth®** function on the mobile phone;
- press the PHONE button on the front panel;
- if no phone is paired with the system yet, the display shows a dedicated screen;
- select "Yes" to start the pairing procedure, then search for the **Uconnect™** device on the mobile phone (if "No" is selected, the Phone main screen is displayed);

- ❑ when prompted by the mobile phone, use its keypad to enter the PIN code shown on the system display or confirm on the mobile phone the PIN displayed;
- ❑ you can always pair a mobile phone from the "Phone" screen by pressing the "Settings" graphic button: press the "Add Device" button and proceed as described above;
- ❑ during the pairing stage a screen is displayed showing the progress of the operation;
- ❑ when the pairing procedure is completed successfully, a screen is displayed: answer "Yes" to the question to pair the mobile phone as favourite (the mobile phone will have priority over all other mobile phones to be paired subsequently). If no other devices are paired, the system will consider the first paired device as the favourite.

NOTE To ensure proper operation after updating the phone software, it is recommended to remove the phone from the list of devices linked to the radio, delete the previous system pairing also from the list of **Bluetooth®** devices on the phone and make a new pairing.

UCONNECT™ 7 HD/ NAV



47

F0S0731



❑ Brief button press: on/off



❑ Turn knob: volume adjustment



Volume activation/deactivation (Mute/ Pause)



Display on/off

 **BACK**

Exit the selection/return to previous screen

SCROLL TUNE

- ❑ Brief button press: Confirm option shown on the display, display station list if in Radio mode, scroll through source contents if in Media mode, open the browsing list if in Radio or Media mode
- ❑ Turn knob: scrolling list or tuning a radio station, change the track in Media sources, changing the radio station if in tuner mode

Graphic buttons on display

Radio

Access to the Radio mode

Media

Source selection: USB, **Bluetooth®**

Phone

Phone data display

Uconnect

Access to the additional functions (e.g. compass display)

Nav (Uconnect™ 7" HD Nav version only)

Access to the navigation function

Settings

Access the settings menu

Trip

Access to the Trip menu

CONTROLS ON THE STEERING WHEEL

See the description in the "Car interior" fig. 1 chapter.

PAIRING A MOBILE PHONE

IMPORTANT Only perform this operation with the vehicle stationary and in safe conditions; this function is deactivated when the vehicle is moving. The pairing procedure for a mobile phone is described below: always consult the handbook for the mobile phone in any case.

To pair the mobile phone, proceed as follows:

- ❑ activate the **Bluetooth®** function on the mobile phone;
- ❑ press the "Phone" button on the display;
- ❑ if no phone is paired with the system yet, the display shows a dedicated screen;

- ❑ access "Settings" and type "Add Device" to start the pairing procedure, then search for the **Uconnect™** device on the mobile phone;
- ❑ when prompted by the mobile phone, use its keypad to enter the PIN code shown on the system display or confirm on the mobile phone the PIN displayed;
- ❑ during the pairing stage a screen is displayed showing the progress of the operation;
- ❑ when the pairing procedure is completed successfully, a screen is displayed: answer "Yes" to the question to pair the mobile phone as favourite (the mobile phone will have priority over all other mobile phones to be paired subsequently). If no other devices are paired, the system will consider the first paired device as the favourite.

NOTE To ensure proper operation after updating the phone software, it is recommended to remove the phone from the list of devices linked to the radio, delete the previous system pairing also from the list of **Bluetooth®** devices on the phone and make a new pairing.

WHEELS

COLD TYRE INFLATION PRESSURE (bar)

175/65 R14 82T (*)

175/65 R14 86T (*)

Medium load (front/rear): 2.2/2.0

Full load (front/rear): 2.3/2.2

185/55 R15 82H

185/55 R15 86H

Medium load (front/rear): 2.2/2.1

Full load (front/rear): 2.3/2.3

195/45 R16 84H (*)

195/45 R16 84V (*)

Medium load (front/rear): 2.2/2.1

Full load (front/rear): 2.4/2.3

Space-saver wheel (for versions/markets, where provided): 2.8

(*) The specified pressure is aimed at comfort. To privilege fuel efficiency, the tyre pressure can be increased to a maximum of 2.8 bar on the front tyres and up to 2.6 bar on the rear tyres.

OFFICIAL TYPE APPROVALS

Radio equipment

All radio equipment provided with the car complies with Directive 2014/53/EU, UA.RED.TR, the French SAR Decree Law of 15/11/2019 and the UKCA (UK Conformity Assessed) Certification of 01/01/2021 in force in the United Kingdom.

For more information about certifications and open source lists available for in-car components use the following link:

<http://aftersales.fiat.com/elum/>.

Radio frequency devices



All radio frequency devices comply with the regulations in force in the countries in which they are sold.

For further information go to www.mopar.eu/owner or <http://aftersales.fiat.com/elum>.

